

Accessibility

EasyPlat, DomoStep and MiniPocket

Platforms for low and high travel





Whether there are a few steps to overcome or a height difference up to 12 meters, AreaLift guarantees the ideal solution for every need.





AreaLift

Range of products for accessibility



DomoFlex



The DomoFlex platform lift is perfect for connecting floors both indoors and outdoors, such as lofts, penthouses, terraces, balconies and all those situations where the fixing points are limited
Maximum travel:
12 meters.

See specific catalog

EasyPlat



Our lifting platform designed for overcoming architectural barriers. Ideal for two people standing or a wheelchair user and another person.
Maximum travel: **3 meters.**

Page 6

AreaLift is the company specialized in the removal of architectural barriers, both in public or domestic premises. Our solutions have a smooth impact in your location thanks to the high designed structures and to the glass surfaces. The whole range can be installed in a few hours or in a few days depending on the needs. All the products require reduced masonry work: we take care of everything!



DomoStep

The open platform, DomoStep 100A is the ideal solution to overcome architectural barriers **up to a meter**, in total safety. Designed specifically for people with reduced mobility or wheelchairs, alone or with another person.



Page 12

MiniPocket

It is the ideal solution to overcome a few steps in all historical or architectural buildings. It offers almost no visual impact; when closed, the platform is hidden in the floor.



Page 16

EasyPlat

Lifting platform without shaft and without wall fixings



Versatile solution

EasyPlat is the lifting platform solution for all environments: your house, the block of flats where you live or all public spaces such as offices, shops or restaurants.

It guarantees full comfort and has been designed to overcome small travel like a few steps or even an entire floor in complete safety as it reaches 3 meters travel.

Why choose EasyPlat

- 🏠 Maximum level of safety
- 🏠 Take advantage of most of available space
- 🏠 Extremely silent
- 🏠 Reduced purchase and maintenance costs
- 🏠 Quick assembly time: maximum 1 day
- 🏠 Italian style, with sophisticated design, LED strips and double controls panels
- 🏠 Absolute absence of masonry works (no pit needed)
- 🏠 Minimal aesthetic impact
- 🏠 Can be installed both outdoor and indoor
- 🏠 Made in Italy: built in Parma with care and passion



Outdoor



Indoor



Suggested
use



Max payload



230 VAC
Single-phase



Stylish for your home

EasyPlat has been designed to fit all environments including your house and your beloved spaces.
The EasyPlat **neat design offers unique details** thanks to the essential and wisely shaped profiles, upper and lower lighting with LED strips and large windows.

Simple, thanks to the absence of masonry works

EasyPlat simply stands on the floor. It has an integrated access ramp and it does not require any pit. Load-bearing walls are not required. EasyPlat only needs minimal space, it does not require a machine room or any external cabinet: **everything is fitted in the installation spaces!**

EasyPlat



Perfect for your block of flats

EasyPlat can be installed in the block of flats where you live to help everyone overcome small travels that make it difficult to move between levels.



EasyPlat is activated touching a button, both in the platform and on the arrival floor. It is equipped with **double control panels on both sides**. The column with wireless buttons can be positioned everywhere on the ground floor.



Functional in any public environment

EasyPlat is the ideal solution to overcome architectural barriers even in public environments. It will ensure easy access for everyone in schools, shops, restaurants and offices.



LED lighting, improves the design of the product and helps to visualize its overall dimensions in the dark ensuring higher safety.

Quick and easy to install

EasyPlat can be installed in a short time:
even in one day!
The main components are pre-assembled supplied to simplify and speed up the installation process.

EasyPlat

Finishes

Steel structure painting



RAL 9010
Pure white

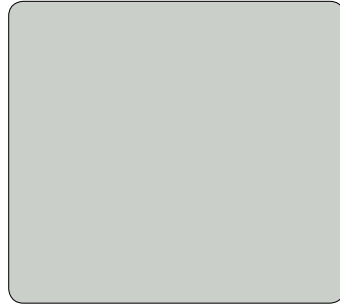

RAL 7035
Light grey - **Standard**



RAL 9006
White aluminium

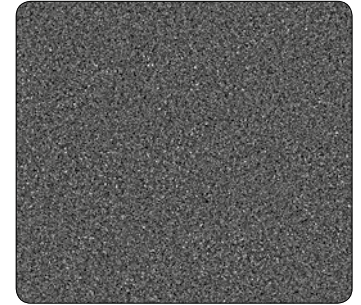

GREY MICA
Grey mica

Glass



Natural
Standard

Floors



Linoleum 3146
Serene Grey

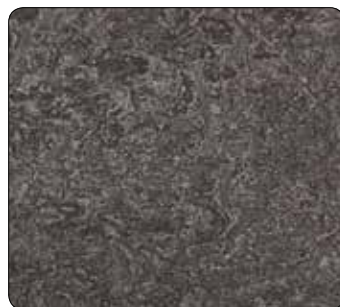

Linoleum 3048
Dark Grey



Linoleum 2939
Black



Aluminium
5 bar aluminium tread plate

COP and buttons



- 🏠 54 x 54 mm control buttons with embossed decoration
- 🏠 Matt steel colour finish
- 🏠 Blue backlight
- 🏠 IP54 protection degree

EasyPlat

Technical specifications

Maximum travel (H max)	3000 mm in private houses 2000 mm in public environments
Load	400 kg
Stops	2 Max
Accesses	Opposite
Controls	Hold-to-run button onboard and on landing
Installation	Indoor or outdoor
Platform dimensions (L1xL2)	1100 x 1400 mm
Minimum headroom required	1800 mm
Pit depth	Not required: integrated ramp Floor height: 70 mm
Traction	Electromechanical motor with belt
Operation	Pressed button
Remote Control	2 pieces kit (included)
Maximum speed	Max 0,10 m/sec (6 m/min)
Cycles/hour	10 max
Power supply	Single-phase 230 Vac
Installed power	1,1 kW
Max. Absorption	16 A
Electrical cabinet	On-board
Traction group	On-board
Reference standard	CE Mark - In compliance to BS6440-2011 and D.M. 2006/42/CE

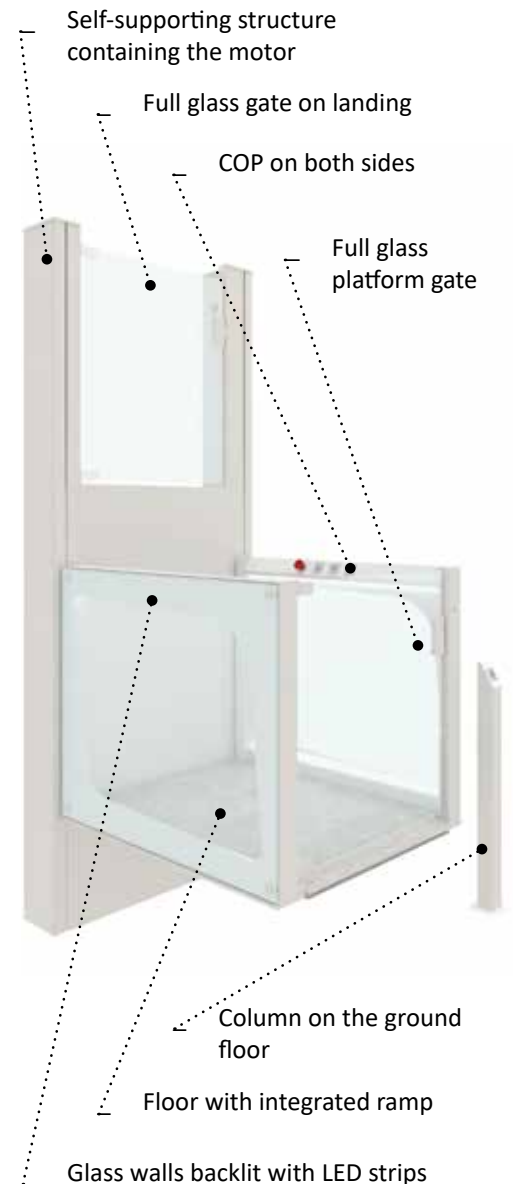

Dimensions

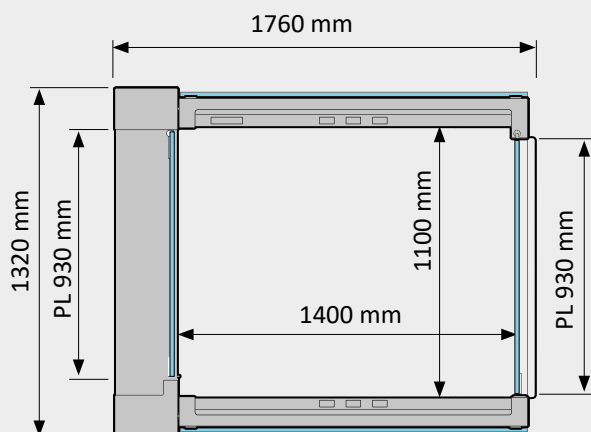

SPECIAL SIZES UPON REQUEST

Column on the ground floor

DomoStep 100A

Open platform without wall fixings



Versatile solution

DomoStep 100A is the ideal solution to overcome architectural barriers **up to one meter in complete safety**. It is designed for people with reduced mobility and using a wheelchair, with or without an accompanying person.

Safety, versatility and reliability, diminished overall dimensions and quick installation are DomoStep 100A strengths.

The platform, in compliance with DM 2006-42-CE, does not need any masonry work; it is battery-powered and does not require any fixed wiring. A standard socket is enough.





Suggested use



Max payload



Stand-By power consumption



In-use power consumption



DomoStep 100A

Finishes

Steel structure painting



RAL 7035
Light grey - **Standard**



RAL Painting
AreaLift range

Floors



Aluminium - 5 bar aluminium
tread plate - **Standard**



N004
Black round studded rubber

Configuration

Safety

- Emergency STOP
- Lowering to landing in case of black out
- Lower sensitive surface (without bellows)
- Inside battery for powerless operation

Platform operating panel

- Standard with n° 5 buttons

Wireless operating panel (kit 2 pieces)

- N° 1 button
- N° 1 hold-to-run key
- N° 1 button + 1 key switch 2P/2E

Landing gate

- BL Blind (painted RAL 7035 Light Grey)
- BL Blind (painted RAL in AreaLift range)
- GL Glazed
- Motorized gate opening system

■ Standard Optional

Protection bellow (in compliance with the current directive)

- 85 mm pit

Protection bar and handlebars

- side fixed handlebar
- Automatic fall-prevent bar

Finishes (balustrade, anti-shearing wall, platform, column and accessories)

- BL Blind (painted RAL 7035 Light Grey)
- BL Blind (painted RAL in AreaLift range)

Platform

- Customized dimensions (within max limits)
- 5 Bar Aluminum tread plate floor
- Round Studded Rubber black floor

Extra version

- OUTDOOR - AISI 316 stainless steel
- OUTDOOR - Electric and Mechanical protection

Dimensions

STANDARD VERSION

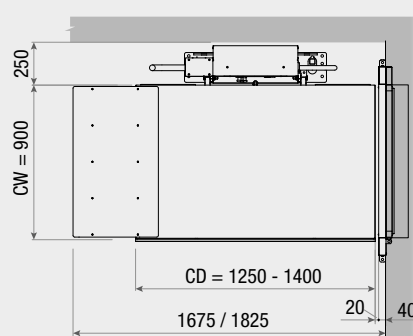
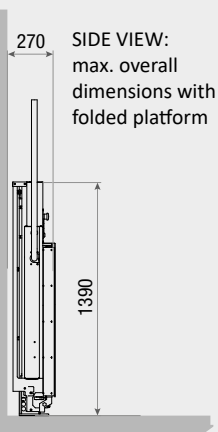

TOP VIEW: max overall dimensions
with unfolded platform

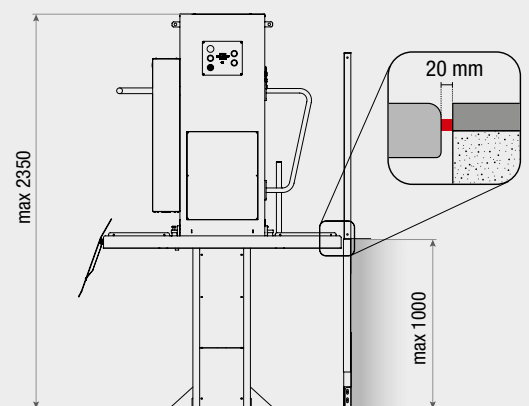

FRONT VIEW:
overall height at max extension

Technical specifications

Maximum travel (H max)	1000 mm
Traction	Hydraulic
Operation	Hold to Run
Speed	5 cm per second
Power supply	Single-phase 230 Vac
Stand-by power consumption	6 W (electrical network supply)
In-use power consumption	46W (electrical network supply)
Cycles /hour	Max 10 (with 250 kg load)
Batteries	2 x 12Vdc 7Ah
Power Unit	Embedded in the column
Platform	Manually foldable (version without balaustrade)
Platform dimensions (L1xL2)*	900x1250 - 900x1400 mm
Remote control	Included (2 pcs)
Fixing (travel ≤ 0,5 m)	Floor fixing
Fixing (travel ≤ 1,0 m)	Floor and wall fixings
Packaging	Wooden Cage

* Customized dimensions (on demand)

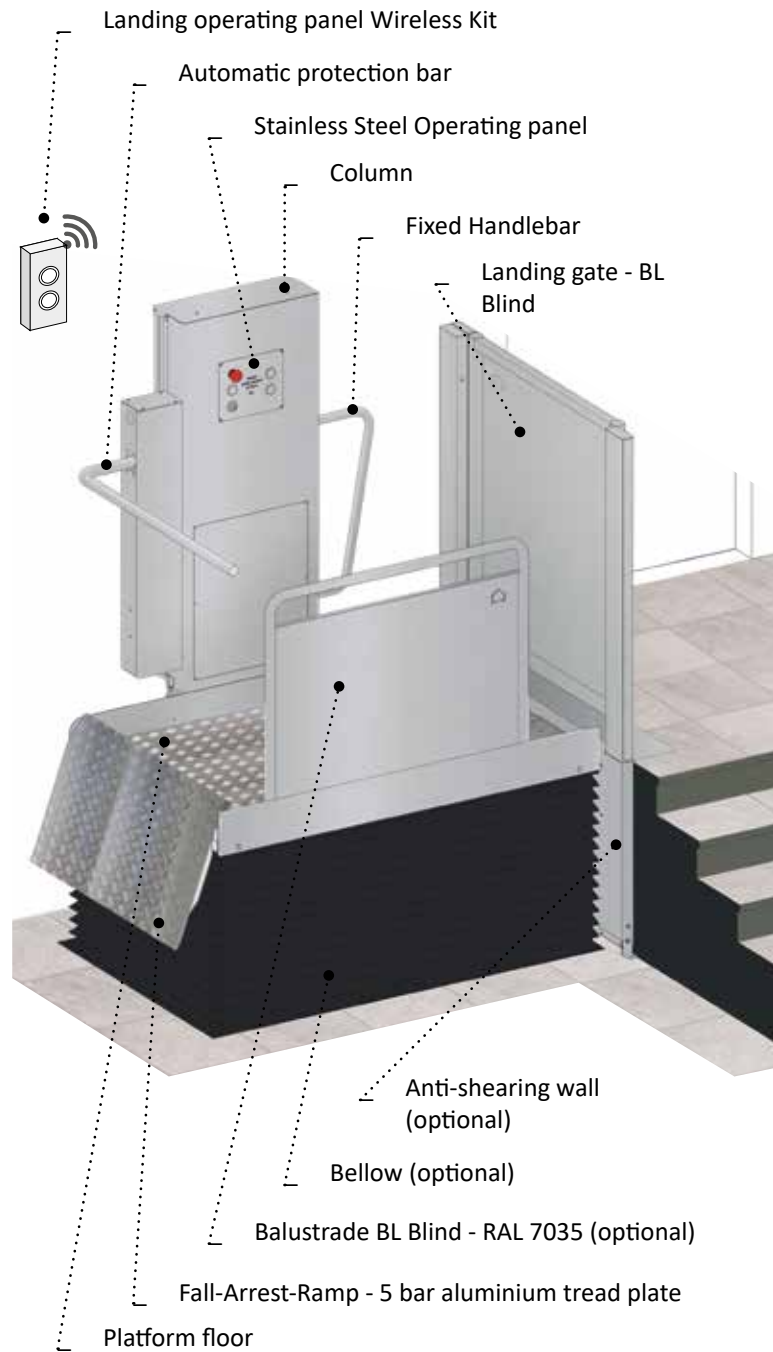
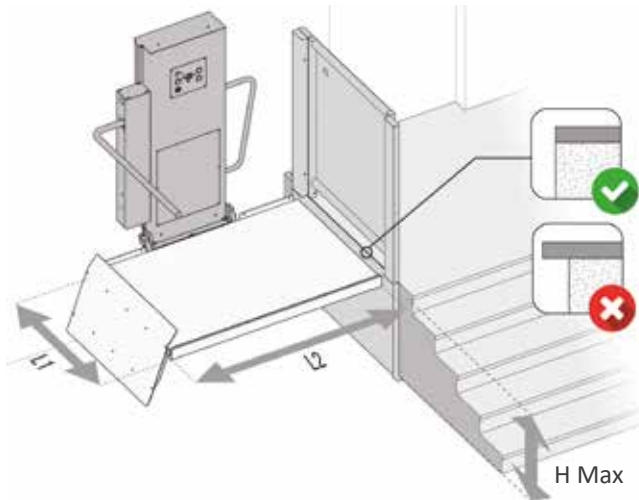

BELLOW VERSION (OPTIONAL)

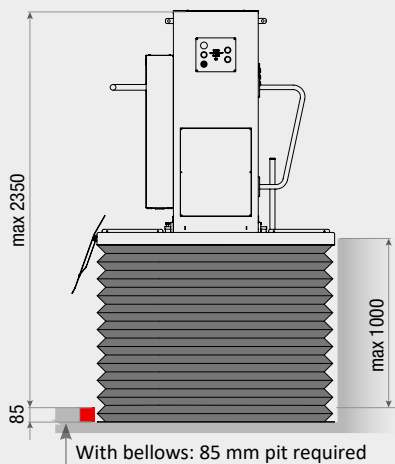
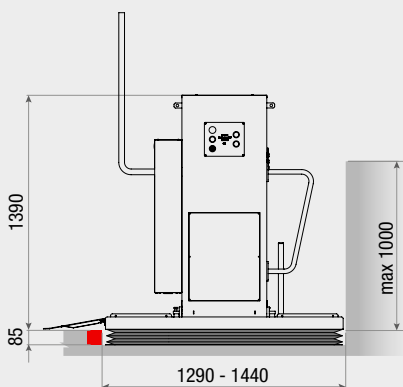

MiniPocket

Scissor platform with combined vertical and horizontal movement



Perfectly integrated

It's the ideal solution to overcome few steps wherever special architectonic commitments are required. Its visual impact is almost insignificant since the platform is embedded in the floor when closed.

Thanks to its constructive features MiniPocket platform makes possible to use the same flooring of the installation site. Once closed, the platform becomes invisible.

Public and private use

Suitable for public and private use to overcome architectural barriers.

Outdoor installation

It can be used outdoor since all material is IP54 certified.



Accessibility



Outdoor



Indoor



Suggested use



Max payload



230 VAC single-phase



Safe and comfortable

MiniPocket platform is designed for users with reduced mobility, with or without wheelchair, and it's equipped with a safety system that ensure its reliability.

Hydraulic scissor platform

Hydraulic scissor technology allows the production of embedded platforms with high payloads and reduced dimensions. Additionally they offer the reliability and safety of hydraulic operation.

MiniPocket

Finishes

Steel structure painting

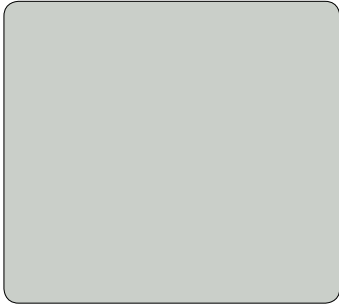

RAL 7035
Light grey - **Standard**



RAL 9010
Pure white

Floors



Aluminium - 5 bar aluminium tread plate - Standard



Floor provided by customer
Max. thickness 30 mm

Platform column

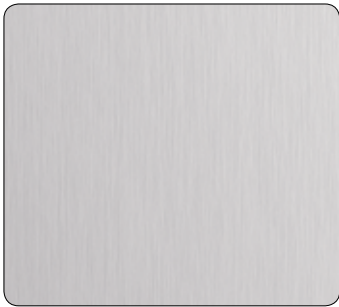

Scotch Brite
Stainless Steel



Configuration

Platform floor

- Anti-slip aluminium
- Floor provided by the customer - 30 mm max thickness (max. 60kg/mq)

Gate for travels > 500 mm

- BL Blind painted (RAL 7035 Light grey)
- BL Blind painted (RAL AreaLift range)
- GL Glazed
- Gate motor

Column

- Platform column without fall protection bar
- Platform column with fall protection bar (travels < 500 mm)
- Platform column with fall protection bar (travels > 500 mm)
- Landing column kit for remote controls

Safety systems

- Black out emergency descent
- Front sensitive edge on the landing access
- Black PVC bellow (on 3 sides)
- Aluminum retractable automatic protection edges on three sides (excluded access side)
- Emergency buttons (STOP and ALARM)
- Low tension control circuits

Accessories / options

- Platform enabling switch key
- Wireless landing push buttons kit (2 pcs.)
- Additional remote control

Standard Optional

MiniPocket

Technical specifications

Max travel	780 mm (H max)
Max horizontal movement	800 mm (T max)
Platform dimensions (L1xL2)	950x1540 mm (std) or 1100x1540 mm (opt)
Pit dimensions	1025x1590 (std) or 1175x1590 mm (opt)
Pit depth	220 mm ^(A)
Traction	Hydraulic scissor
Operation	Hold to run
Remote control	2 pcs. Included
Max speed	5 cm/s
Cycles per hour	10 max
Power supply	230 Vac single-phase
Rated power	370 W
Max electrical absorption	2 A
Control panel	In separate machine room
Hydraulic system	In the pit
Reference Standard	D.M. 2006/42/CE

(A) If the floor is provided by the customer please add 30 mm (max 60 kg / sqm)

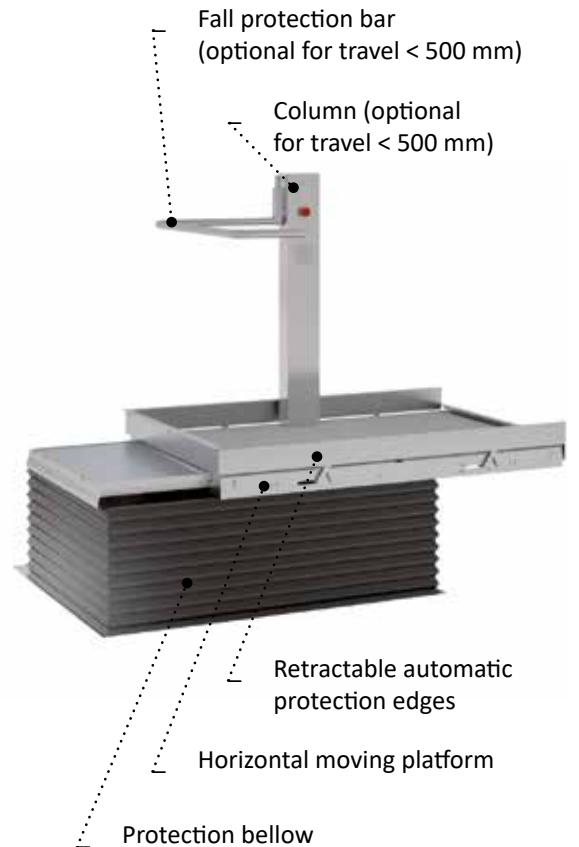

Dimensions

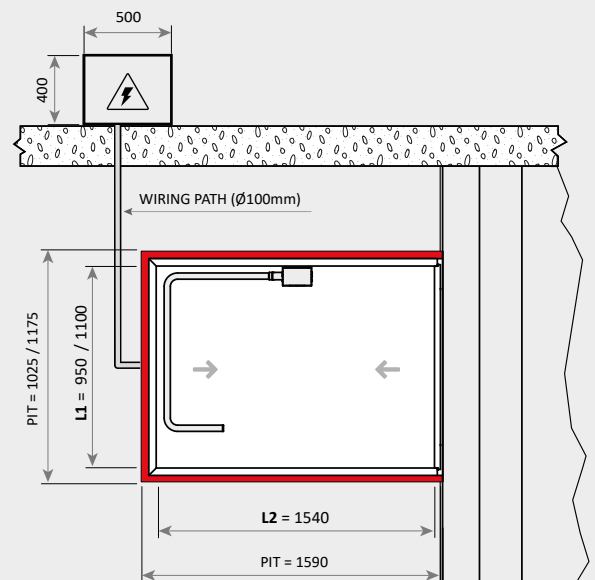
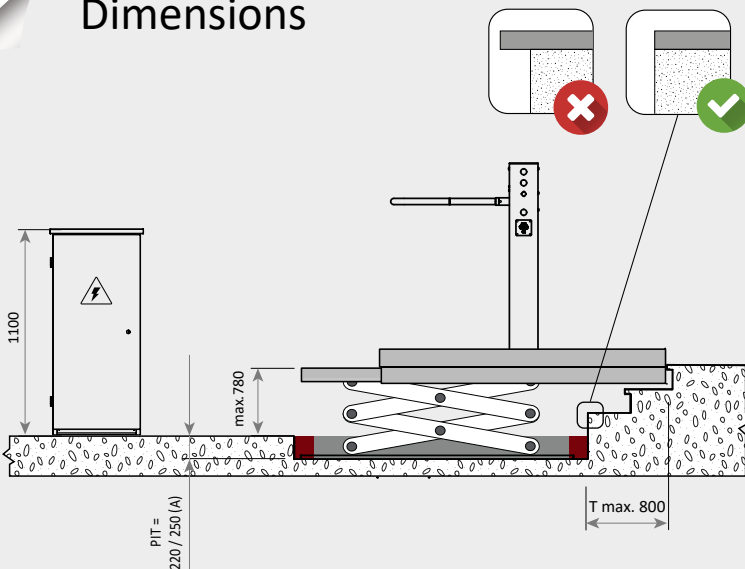

Who we are

AreaLift is a young company established by professionals with long experience in the vertical transport sector.

AreaLift is specialized in the design and production of home and platform lifts to overcome differences in height up to 12 meters.

Our products are sold in over 30 countries worldwide!

Made in Italy

What makes us unique is the Italian style and the attention to quality which comes from our history as a manufacturing company.

Functional and comfortable, AreaLift's lifting platforms allow you to move easily, in perfect autonomy and with the charm that distinguishes the Italian style.

LiftingItalia and AreaLift

The group consists of two young and dynamic companies that work in perfect synergy completing each other.

LiftingItalia - Established in 2003, is the parent company and today is specialized in the production of **high quality homelifts**.

AreaLift - Established in 2003, is a company **specialized in accessibility solutions and vertical mobility**.



AREALIFT S.r.l.

Via Caduti del Lavoro, 22
43058 Bogolese di Sorbolo - Parma, Italy
Tel. +39 0521 695311



Authorized reseller