



SHANGHAI
MITSUBISHI
ELEVATOR



Technological Innovations
High Levels of Comfort

LEHY-III-S

LEHY · Compact Machine Room
Passenger Elevator

Technological Innovations for High-Levels of Comfort

LEHY-III-S is a new generation of elevator with standard compact machine room system developed by Shanghai Mitsubishi Elevator Co., Ltd. to satisfy the needs of the residential elevator market. With higher technological content and decoration quality as well as cutting-edge technologies, LEHY-III-S is dedicated to providing a superior quality of service tailored to accommodate your needs, so as to provide a comfortable, quiet and user-friendly ride.

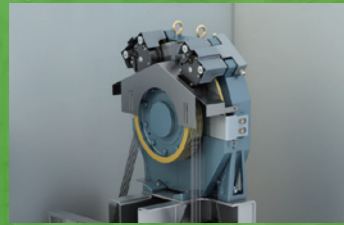

Cutting-edge Technologies All in One

LEHY-III-S is equipped with new-generation PM synchronous gearless traction machine and ultra-slim PM door operator.



Top Quality with Enhanced Ride Comfort

We strive for excellence in all aspects of material selection, R&D, manufacturing, etc., use high-quality components, and deliver excellent installation and maintenance services to ensure a quiet, comfortable and reliable ride for a long time.



User-Friendly Designs for Higher Quality of Life

Close to the passenger preferences of high-quality projects, select warm, simple and lively decoration design styles for you; a variety of car specifications, as well as configurations that meet the requirements of the disabled, can be selected to meet different needs.

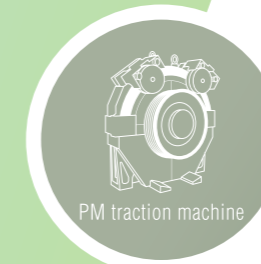
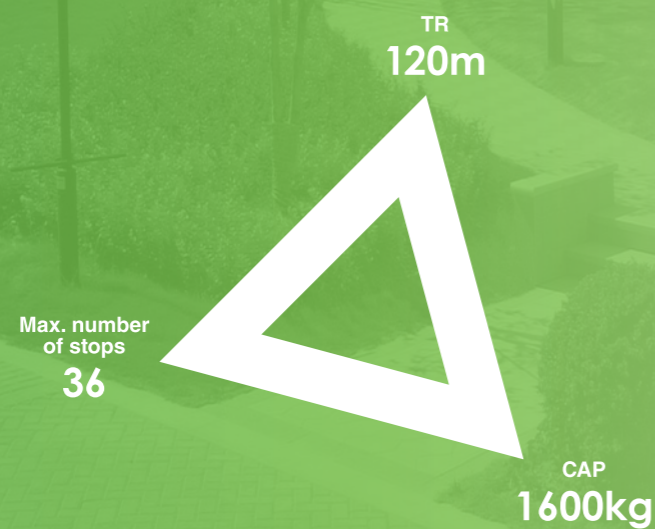

CONTENTS

- Cutting-edge Technologies 01
- Top Quality 03
- Flexibility / Availability 05
- Clean Technology 07
- Car decoration material 08
- Ceiling 09
- Diversified button 10
- Car Operating Panel 11
- Hall Position Indicators and Buttons 13
- LCD Indicators 14
- Hall Doors and Jamb 15
- Basic Specifications 16
- Features List 17
- Safety and Harmony 20

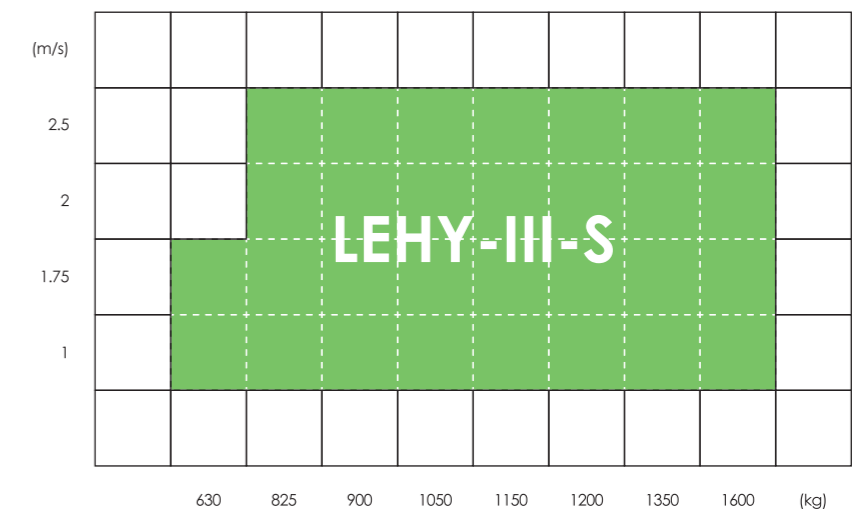

Cutting-edge Technologies

New-generation Traction Machine with PM Motor

LEHY-III-S uses new-generation PM traction machine with built-in joint-lapped stator core. Specially optimized for compact machine room elevators and with easy-to-maintain external brakes, the new traction machine is more energy-saving, simple in structure and easy to maintain while maintaining the high level of quality and performance of the original machine. Based on disc brake and current control technology with lower noise, brakes do not make the elevator come to an emergency stop and creates lower noise when holding, providing passengers with a more comfortable and quieter ride experience.

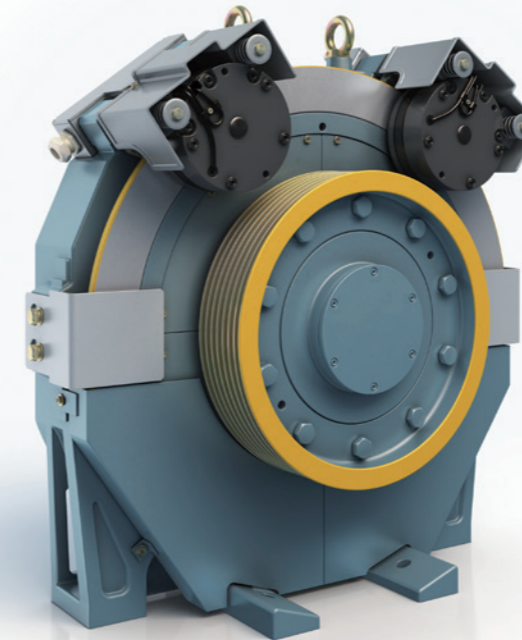

Patented Joint-lapped Stator Core Technology

Uniform winding and high-density coils significant increase magnetic flux and output torque, thus improving performance and efficiency.

PM Gearless Traction Machine

A PM traction machine does not require additional excitation current and rotor consumption, thus saving about 30% on energy consumption compared to a conventional worm-gear traction machine.

Brake Current Control technology

With accurate close-loop current control, brakes create lower noise and impact when working, which reduces wear on components and improves ride comfort.

Intelligent, Quiet Ultra-slim PM Door Operator System

The entire series adopts a direct-drive ultra-slim PM door operator, which integrates 32-bit high-speed digital signal processors, double-closed loop control with current and speed feedback, and variable voltage, variable frequency (VVVF) regulation system, enabling the door operator system to run in a more energy-saving manner, making doors open and close more stably and maintenance easier, and saving the space required for installation.

Intelligent Door Opening and Closing Torque Control

The door operator control system collects the data of changing door weight and door opening/closing resistance at each landing, so as to ensure doors open and close smoothly, reliably and safely.

Ultra-slim Integrated Structure

LEHY-III-S adopts direct-drive PM door motor and integrated door guiderails, which saves the reducer and the connecting rod and minimizes the space required to install the door operator.

Door Opening and Closing Noise Control [Max<59dB(A)]

LEHY-III-S uses variable voltage, variable frequency regulation technology to provide passengers with comfortable, quiet ride experience, with the maximum noise level less than 59dB(A) [national standards for noise: 65dB(A).]

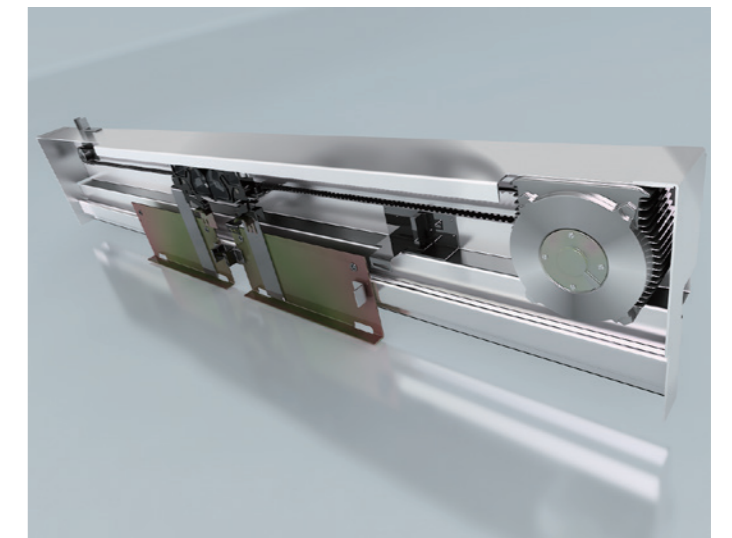

Energy Feedback Technology (Optional)

With energy feedback technology based on PWM (optional), the power generated during traction machine operation is fed into the electrical network in the building. Compared to the same type of elevator without an energy feedback device, this system provides an energy-saving effect of approximately 30%. Meanwhile, the incoming current of the power supply side is in sinusoidal waveform, greatly decreasing harmonic currents; the DC voltage is controlled, helping to improve the stability of elevator operation.

All-digital Intelligent Power Supply System

All-digital intelligent power supply technology replaces the three-phase power transformer to power the elevator control system. The new system is more stable and reliable, less susceptible to the fluctuations of the electrical network in the building, and delivers a less use of energy, higher efficiency and better protection.

Car Slide Safety Protection

When the car slides due to insufficient braking force to the extent that the power elements can stand, the three-phase winding of the PM traction machine is shorted to reduce the speed the car slides so as to improve safety.

Multiple Braking Torque Detection Protection

Features including Double-Side Static Torque Detect-Periodic (DBSD-P), Double-Side Static Torque Detect-Power-on (DBSD-O), Double-Side Static Torque Detect-Manual (DBSD-M) and Single-Side Static Torque Detect-Manual (SBSD-M) provide better braking torque detection protection and ensure passengers' safety.

Top Quality



We are always committed to providing a safe, comfortable ride for users and strive for excellence in all aspects of R&D, manufacturing, installation, maintenance, etc. Packed with cutting-edge technologies, high-quality and reliable components, LEHY-III-S elevators level accurately and provide a safe, comfortable ride.

Intelligent Traction Machine Production Line

Compared to the conventional mode of production, the global leading intelligent traction machine production facilities are safer and more reliable.

Brake Reliability Test (over 15 million times)*1

Brakes have undergone over 15 million times of static action tests, which ensures the brakes still function during long-term heavy load operation so as to avoid risks like elevator drop and ensure safety.

High-quality Slim Control Panel

With world famous electronic components, contactors/relays and power modules and through seamless integration of elevator operation management, control, drive and communication modules, the control panel is made digital, modularized and slim, with improved reliability and anti-interference capability.

Button Reliability Test (over 5 million times)*1

Buttons adopt the anti-drop design and can withstand rough use. After 5 million times of action tests, buttons are stronger and more durable and less likely to be damaged during the entire elevator lifecycle.

Class A Energy Efficiency

The new-generation digital power supply system delivers markedly improved power usage effectiveness. All lighting uses LED power source, and technologies including car lighting, CFO-A and energy-saving hall position indicators are used, greatly enabling a lower use of energy standby mode.

PCBs Withstand 10 Severe Reliability Tests*1

After ten severe reliability tests, including temperature change, temperature/humidity (cyclic), damp heat (steady state), critical temperature change, critical high temperature and high humidity, limit temperature change, sinusoidal vibration, shock, bump, dust and sand, PCBs still function properly so as to ensure the "brain" of each elevator can withstand harsh working conditions.

Note *1:

- The above test data is listed in the corresponding test report. Due to restrictions on test conditions and methods, indicators achieved by test samples cannot represent the actual indicators of the products but can reflect the overall quality of the products.
- The above test results do not exempt the users from responsibilities of using, managing, maintaining and ensuring the safety of the elevators according to law.

The picture is a schematic rendering. The size and appearance may vary according to actual specification and configurations.

Flexibility / Availability

With the same size as the hoistway, the machine room of LEHY-III-S elevators is really compact, which saves the actual space required for machine room and increases the utilization of the building. Architects and interior designers have more design freedom.

Wider Range of Specifications

Cars of various specifications are available to satisfy users' needs, for example deep car (stretcher elevator), and comply with the latest elevator standards (elevators for persons with disabilities, which can be configured at your cost). Users can select three cars group control (non-standard confirmation is required).

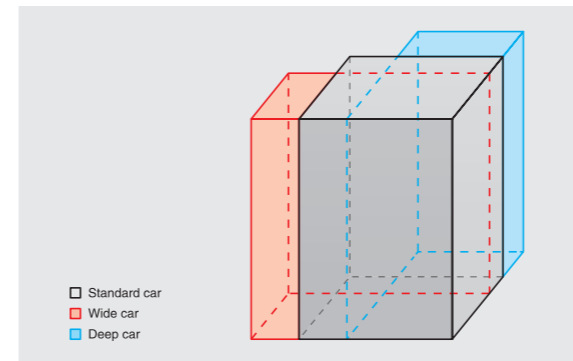

Through Door

To satisfy the needs for "Elevators go directly to the home" in high-end residences, new through-door elevators are optional, which offers more design freedom to architects and interior designers, reduces the shared public area, and ensures the privacy of high-end home owners.

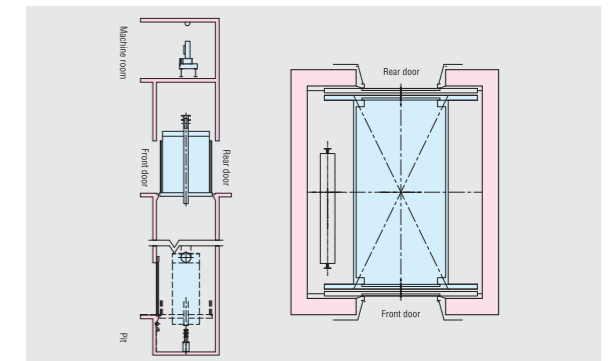

Patented LCD Technology

With delicate interface design and eye-catching background colors, the full-view high-quality screen is highly visible in the sunlight and its graphical display of status is easy to understand.



Easy-to-Install Wall-Mounted Hall Fixtures

The bottomless box buttons can be easily mounted through a small round opening on the wall surface, without having to cut into the wall to embed the back box.

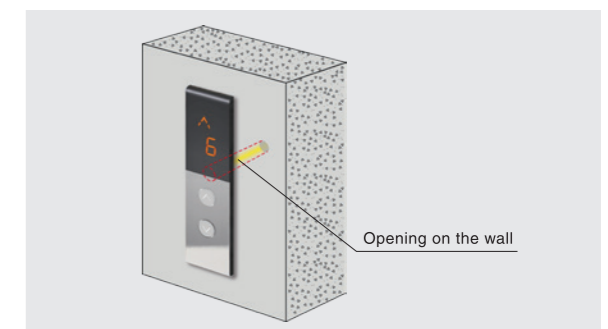

Barrier-Free Design

In light of the requirements of persons with disabilities including mobility impairments, wheelchair operating panels, mirrors, handrails and other barrier-free designs are available for selection, so as to create a loving and caring environment and a safe, convenient and comfortable ride for passengers.



Button Glimmering Design in Standby Mode

The buttons glimmer in standby mode to make floor numbers easier to identify even in the dark.

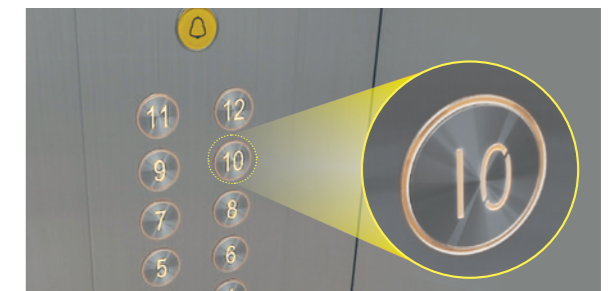

Clean Technology

Water Ion Air Conditioner and Water Ion Fan

Cleaner

- Equipped with Panasonic nanoe™X water ion generator imported from Japan, which can kill attached bacteria and viruses.
- Equipped with high-sensitivity VOC sensors, which enable the fan to switch to the maximum speed for quick ventilation when smoke or unpleasant smell is detected.

More user-friendly

- Fan speed can be adjusted according to the load: The fewer the number of passengers is, the slower and the quieter the fan is.
- Fan speed can also be adjusted from a mobile app.

Concentration of bacteria (cfu/Gauze)

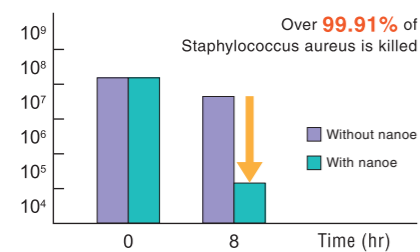

Number of virus infections (TCID 50/mL)

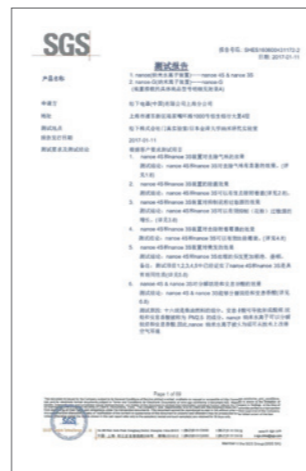
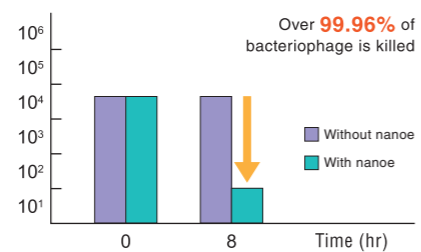

Introduction to nanoe™X technology

- nanoe™X are water-wrapped nano-sized particles, which can kill the attached bacteria and viruses by denaturing their protein.
- The eight-hour nanoe™X test in a 23.3 m3 lab has proved that, nanoe™X can kill up to 99.91% of Staphylococcus aureus.
- The eight-hour nanoe™X test in a 23.3 m3 lab has proved that, nanoe™X can kill up to 99.96% of bacteriophage.
- nanoe, nanoe™X, nanoe label, and nanoe™X label are trademarks of Panasonic Corporation.

Intelligent UV Germicidal Lamps (optional)

Highly-efficient sterilization

After radiating the surfaces of operation panel and handrail for 12min, the killing rate of Escherichia coli is 99%.
(the above data based on CAP 1050 kg elevator)

Intelligent UV Germicidal Lamps

Easy to install and modernize

Drill holes on the ceiling plate to install screws, Power cables connected to the lighting wiring terminal.

Product appearance design

The lighting cover is translucent and can protect the tube. Located at the front of the car; not eye-catching.

Product function design

Normal and enhanced mode available for selection; a remote available to turn on/off the lamps and switch modes, display the status and fault, replace the tubes, etc.

Double protection

Start only when the elevator sleep light is off, Stop when infrared sensors detect passengers.

Car decoration material

Handrails

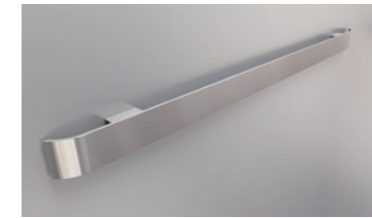

ZYH-FH10 (Optional)

Flat stainless steel handrails.

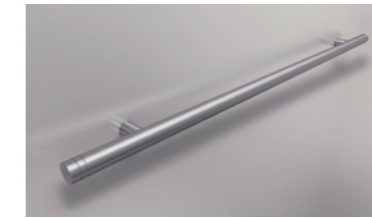

ZYH-RH05/RH05B (Optional)

Round stainless steel handrails.

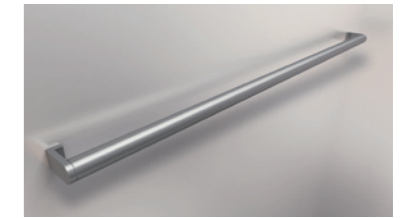

ZYH-RH06/RH06B (Optional)

Round stainless steel handrails.

Note: Titanium coated stainless steel is alternative for handrail ZYH-FH10,ZYH-RH05,ZYH-RH06. Please refer to material table for details of titanium color code.

Mirrors



ZYZ-01A (Optional)

Half mirror.



ZYZ-03S (Optional)

Full-height mirror.



ZYZ-04S (Optional)

Stainless steel.

PVC Floor

Imitation marble is featured by clear texture and good gloss. It has upgraded wear resistance and foot feeling, easy maintenance, and impact resistance.

(Note: There may be slight printing marks on the surface, which is a normal phenomenon)



ZPH-035

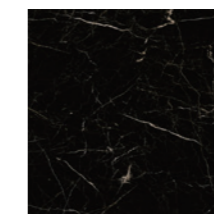

ZPH-036

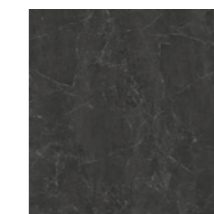

ZPH-037



ZPH-038



ZPH-026

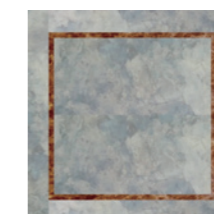

ZPH-029



ZPH-034

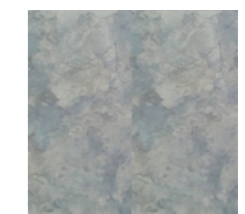

ZPH-031

Note:
Please refer to "Color Sample" for color code.

The picture is a schematic rendering. The size and appearance may vary according to actual specification and configurations.

Ceiling

ZCL-SS12 (Standard)



Material: Coated steel plates for surrounding ceilings, with mirror titanium-plated stainless steel frame.

Thickness: 100mm.

Remark: Thin ceiling, with car internal height increased. The appearance is simple, versatile, anti-collision and easy to repair.

ZCL-SS10 (Standard)



Material: Coating steel sheet.

Thickness: 100mm.

Remark: Thin light guide plate at the center, supported by ambient lights on both sides, which increased the car atmosphere.

ZCL-SS08 (Standard)



Material: [Center] Milky white printed lighting panel; [Sides] Painted steel sheet.

Thickness: 200 mm.

Remark: Central printed lighting board improves the quality of lighting board.

ZCL-SS07S (Optional)

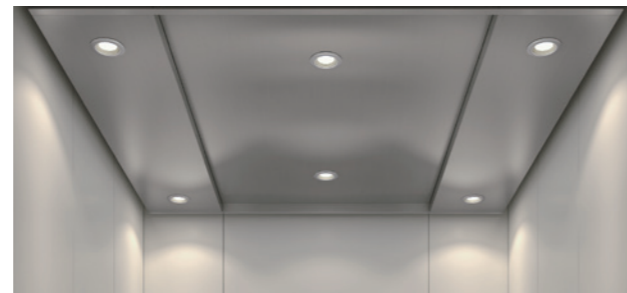

Material: Hairline stainless steel.

Thickness: 100 mm.

Remark: Thin ceiling, with car internal height increased. Hairline finished stainless steel material, durable and easy to maintain.

ZCL-GS18 (Optional)

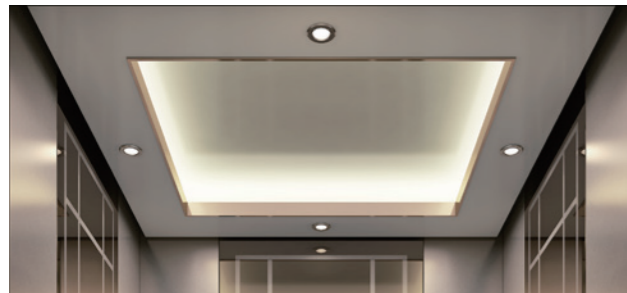

Material: Ceiling: painted steel sheets all around; mirror-finish titanium plated stainless steel frame.

Thickness: 200 mm.

Remark: The rectangular-ambulatory-plane luminous structure improves the height of the space and increases the car atmosphere.

ZCL-GS06 (Optional)



Material: Central milk white printed lighting board, ambient metallic painting steel sheet, translucent plates on both sides.

Thickness: 200 mm.

Remark: The zigzag structure is simple and elegant. Large area lighting at the center, matched with decorative hanging blocks on both sides, enhances the sense of quality.

Notes:

1. LED lighting is used for car top.

2. Air vent for car top is available at the rear of both sides. Safety windows are optional. Please consult our local agents for details.

3. ZY015 is the default color number for ZCL-SS10, and Y033 for ZCL-SS08, ZCL-SS07 and ZCL-GS18. If other colors are required for painted steel sheets, see the decoration color scheme of SMEC.

Ceiling

ZCL-GS22 (Optional)

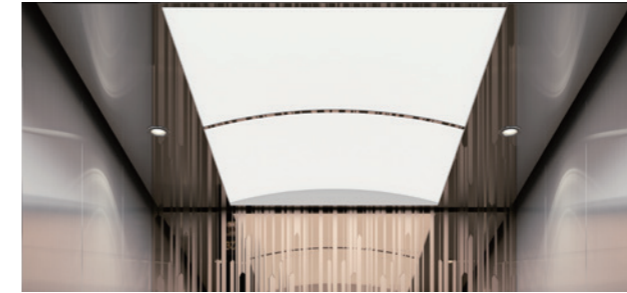

Material: Central milky white arched lighting panels; mirror-finish stainless steel on two sides.

Thickness: 200 mm.

Remark: Large-span arched lighting board improves the height of space. Anti-glare downlights effectively alleviate the glare problem.

ZCL-GS24 (Optional)

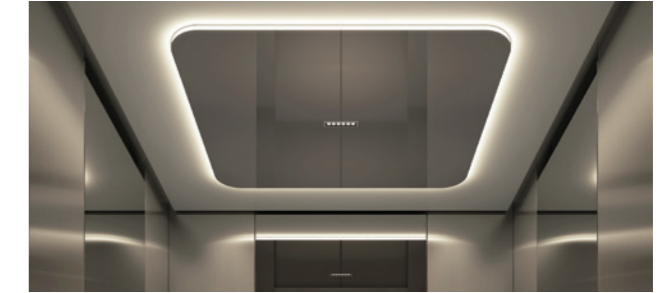

Material: Sand textured stainless steel at the center, and coated steel plates surrounding.

Thickness: 200 mm.

Remark: Thin ceiling, with car internal height increased. The linear light outlines the rounded elements to flood the surroundings, and the center is matched with a module light. Effectively solve the problem of dust accumulation and facilitate inspection.

ZCL-CN01 (Bare ceiling)

If the ceiling is to be decorated by the customer, its thickness must be at least 100 mm; otherwise, the internal structure will be exposed, affecting the look of the ceiling.

ZCL-CN08 (Bare ceiling)

If the ceiling is to be decorated by the customer, its thickness must be at least 200 mm; otherwise, the internal structure will be exposed, affecting the look of the ceiling.

Diversified button



A11 White (Standard)

Φ35 mm, mechanical inching.
Flat characters; glimmering on standby.
Stainless steel surface.



A12 Orange (Optional)

Φ35 mm, mechanical inching.
Flat characters; glimmering on standby.
Stainless steel surface.



A14 White (Optional)

Φ35 mm, mechanical inching.
Raised characters with Braille;
glimmering on standby.
Stainless steel surface.



A15 Orange (Optional)

Φ35 mm, mechanical inching.
Raised characters with Braille;
glimmering on standby.
Stainless steel surface.



A64 White (Optional)

Φ35 mm, mechanical inching.
Raised characters with Braille;
glimmering on standby.
Stainless steel surface; antibacterial.

Car Operating Panel

Front return panel/Side wall mounted full-length operating panel

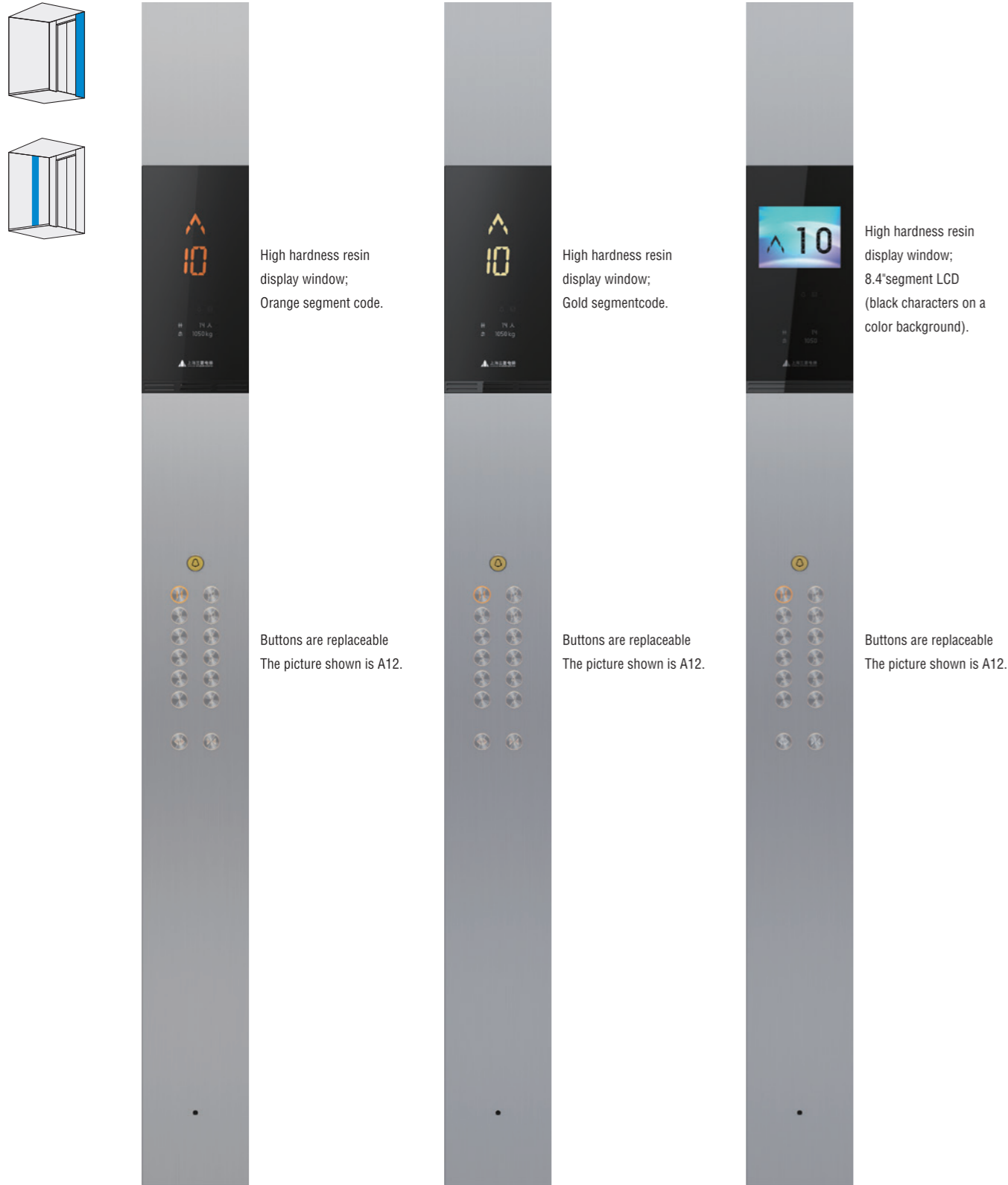

High hardness resin display window;
 Orange segment code.

Buttons are replaceable
 The picture shown is A12.

High hardness resin display window;
 Gold segment code.

Buttons are replaceable
 The picture shown is A12.

High hardness resin display window;
 8.4-segment LCD
 (black characters on a color background).

Buttons are replaceable
 The picture shown is A12.

ZCB■-ND10 (Main) (Standard) ZCB■-ND11 (Main) (Optional) ZCB■-N612 (Main) (Optional)
 ZCB■-ND60 (Auxiliary) (Standard) ZCB■-ND61 (Auxiliary) (Optional) ZCB■-N662 (Auxiliary) (Optional)

Notes:
 For front wall ≥ 250 mm, install the operating panel on the front wall; for front wall < 250 mm, install the operating panel on the side wall.
 The symbol ■ refers to the button model. Please select it from the "Diversified button" page.

Car Operating Panel

Front return panel full-length operating panel



High hardness resin display window;
 8.4-segment LCD
 (black characters on a color background).

Buttons are replaceable
 The picture shown is A11.

ZCB■-T611*1 (Main) (Optional) ZCB■-ND30*1 (Main) (Optional)
 ZCB■-T661*1 (Auxiliary) (Optional) ZCB■-ND80*1 (Auxiliary) (Optional)

Notes:
 *1. Comply with GB/T 24477.
 Hairline-finish, mirror-finish, random pattern and sand pattern stainless steel can be used for the faceplate of the operating panel.
 Non-standard confirmation is required for titanium plated stainless steel.

Side wall mounted full-length operating panel



High hardness resin display window;
 Orange segment code.

A04 and A05 buttons are available for selection.

Wheelchair operating panel

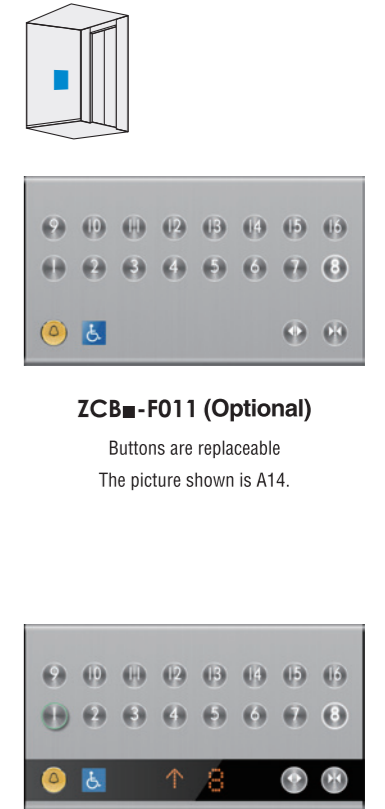

ZCB■-F011 (Optional)

Buttons are replaceable
 The picture shown is A14.

ZCB■-F131*1 (Optional)

Buttons are replaceable
 The picture shown is A14.

More durable buttons
 Buttons have specially designed enhanced stainless steel button caps and adopt anti-drop design to withstand rough use, more durable.

Hall Position Indicators and Buttons

Simple style

Ultra-slim wall-mounted hall position indicators follow SMEC's conventional design—simple but informative, and display information with brand new arrows.

Orange Segment Display



ZPI-GD10 (Standard)
(Single control); Orange segment code; Wall-mounted (without bottom box); Buttons are replaceable The picture shown is A12.

ZPI-GD20 (Standard)
(Duplex control); Orange segment code; Wall-mounted (without bottom box); Buttons are replaceable The picture shown is A12.

Segment LCD



ZPI-GB13 (Optional)
(Single control); 4.3" segment LCD (black characters on a color background); Wall-mounted (without bottom box); Buttons are replaceable The picture shown is A11.

ZPI-GB23 (Optional)
(Duplex control); 4.3" segment LCD (black characters on a color background); Wall-mounted (without bottom box); Buttons are replaceable The picture shown is A11.

Gold Segment Display (embedded)



ZPI-CD12 (Optional)
(Single control); Gold segment code; Embedded, with a bottom box; Buttons are replaceable The picture shown is A11.

ZPI-CD22 (Optional)
(Duplex control); Gold segment code; Embedded, with a bottom box; Buttons are replaceable The picture shown is A11.

Foot-activated call



ZHB-E08-G012 (Optional)
Foot-activated call to create a hand-free experience; Registering car calls with a foot movement.

Hall Call



ZHB-H030 (Optional)
(Single control) Standard button sound; Wall-mounted (without bottom box); Buttons are replaceable The picture shown is A15.

ZHB-H041 (Optional)
(Duplex control) Standard button sound; Wall-mounted (without bottom box); Buttons are replaceable The picture shown is A15.

Hall lantern



ZHLV-H040 (Optional)
with a bottom box
Mist white acrylic light part
The dimension is generous 55x430mm

Notes:

The symbol ● refers to the button model. Please select it from the "Diversified button" page.

Hairline-finish and mirror-finish stainless steel are available for the faceplate of the call buttons of the hall position indicator. Non-standard confirmation is required for titanium plated stainless steel.

ZHB-H030/041 complies with GB/T 24477, and A14/A15 buttons are available. Technical confirmation is required to determine whether the complete elevator meets the standard.

▶ **Simple design**
Follow SMEC's conventional design; Simple but informative.

▶ **Segment LED indicators and LCD indicators**
Display information with brand new arrows, Amber segment LED indicator/patented LCD indicator.

▶ **Screw-free design**
Screw-free design, Easy to maintain.

▶ **Replaceable button caps**
Stainless steel hairline-finish button caps by default, durable.

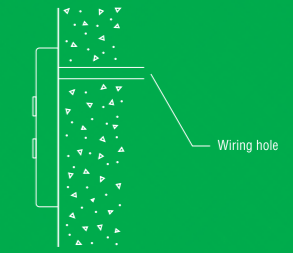

Cross-section of boxless hall signal fixtures

These hall signal fixtures can be easily mounted on the wall surface without having to cut into the wall to embed the back box.

LCD Indicators

Patented LCD technology: creative interface, full-view and high-contrast.

4.3-inch LCD



Eye-catching background colors.
Number horizontally centered.

5.7-inch LCD



Full-view high-quality screen highly visible in the sunlight.
Graphical display of status easy to understand.
Delicate interface design.

Patented font; letters/numbers displayed.



Basic Specifications

Item	Specifications				Remarks
Rated speed (m/s)	1.0	1.75	2.0	2.5	
Rated capacity (kg)	630	630	-	-	
	825	825	825	825	
	900	900	900	900	Only for CWT rear drop.
	1050	1050	1050	1050	
	1150	1150	1150	1150	
	1200	1200	1200	1200	When capacity is 1200 ~ 1600kg, the max. decoration weight is 450+kg, and the max. height of empty ceiling is 3000mm.
	1350	1350	1350	1350	
	1600	1600	1600	1600	
Number of stops	18	32	36	36	
Range of standard travel rise (m)*1	3.4~55	7.3~90	9.1~120	13.3~120	
Start frequency (times/hr)	120	150	180	180	
Operating mode	1C-2BC, 2C-SM21, 2C-4C-ITS-21				
Control mode	VFJ-L				
Roping	2:1(single-wrap)				
Traction machine	PM synchronous gearless traction machine				
Steel wire rope	Φ8, Φ10				
Machine room	Compact machine room				
Balancing compensation device	Chain-type, compensating cable-type				
Door opening method	CO				Depends on car specifications.
	2S				Depends on car specifications.
Door drive mode	VWF (PM door operator)				
Door opening type	Standard: Single entrance (1D1G)				
Three-phase powersupply	380V50Hzthree-phasefive-wire				Power supply requirement: The fluctuation of the supply voltage in relative to the rated voltage should be within -15%~+10%.
Lightingpower	220V50Hzsingle-phase				
CWT position	Rear drop				
	Side drop				
Safety gear (car)	Progressive				
Safety gear (CWT)	Progressive				Optional.
Min. floor height (mm)	2600: Steel landing sill bracket (by SMEC)*2				
	2800: Concrete landing sill bracket (by owner)*3				
Range of floor display	B1, B2, B3, B4, B5, B, G, M, -1, -2, -3, -4, -5, 1, 2, 3, 4, 5, 6, 7, 8, 9, 10, 11, 12, 13, 14, 15, 16, 17, 18, 19, 20, 21, 22, 23, 24, 25, 26, 27, 28, 29, 30, 31, 32, 33, 34, 35, 36, 37, 38, 39, 40, 41, 42, 43, 44, 45, 46, 47, 48;				
	3A, 5A, 12A, 12B, 13A, 15A, 17A, 23A				

Hall Doors and Jamb

E-102 Narrow jamb



Doors: Hairline stainless steel;
Jamb: Hairline stainless steel;
Hall position indicator and button: ZPIA09-GD10.

E-302 Inclined (10°)wide jamb



Doors: Hairline stainless steel;
Jamb: Hairline stainless steel;
Hall position indicator and button: ZPIA11-GB10.

Notes:

*1. If it exceeds the specifications listed in the sample, please contact Shanghai Mitsubishi Elevator Co., Ltd., and the details are subject to the contract signed by both parties.

*2. In general, the minimum floor height is (HH) + 700 mm (for concretelanding sill bracket).

*3. Only applicable when the minimum floor height (HH) is 2100; otherwise technical confirmation is required; when the minimum floor height (HH) is less than 2800 mm, steel landing sill bracketsare required.

For requirements of power supply and environment, please consult our business department.

The picture is a schematic rendering. The size and appearance may vary according to actual specification and configurations.

Feature	Description	Code	1C-2BC	2C-SM21	2C-4C-ITS-21
■ Control and Safety Features					
Automatic Landing with Rheostatic Leveling	When the car lands at a station, if the vertical difference between the upper plane of the car sill and that of the landing door sill exceeds the pre-set value, the elevator will level automatically.	ARL*1	Ⓢ	Ⓢ	Ⓢ
Anti-Stall Timer	When the traction rope slips or when the motor stalls and this lasts for a preset period of time, the elevator will stop.	AST	Ⓢ	Ⓢ	Ⓢ
Brake Redundancy Protection	When one group of brakes fails, other brakes can effectively stop the elevator.	BTUP	Ⓢ	Ⓢ	Ⓢ
Car Slide Safety Protection	When the car slides due to insufficient braking force, in normal power supply, the three-phase winding of PM traction machine is shorted to reduce the speed the car slides.	CSSP	Ⓢ	Ⓢ	Ⓢ
Door Interlock Bypass Operation	To facilitate the maintenance of hall door contact, car door contact and door interlock contact, the hall door or car door safety circuit is bypassed via the door interlock bypass device.	DBO	Ⓢ	Ⓢ	Ⓢ
Double-Side Static Torque Detect (Manual)	When entering Double-Side Static Torque Detect (Manual) mode via manual operation, the elevator keeps all brakes in holding state and applies a torsional torque onto the PM traction machine to check the static torque.	DBSD-M	Ⓢ	Ⓢ	Ⓢ
Double-Side Static Torque Detect (Power-on)	In auto mode, when the elevator is powered on in case of power outage or after the control PCB is reset, the elevator keeps all brakes in holding state and applies a torsional torque onto the PM traction machine to check whether the double-side static torque meets the requirement.	DBSD-O	Ⓢ	Ⓢ	Ⓢ
Double-Side Static Torque Detect (Periodic)	In auto mode, after a certain period of time, when the elevator enters the sleep mode, the elevator keeps all brakes in holding state and applies a torsional torque onto the PM traction machine to check whether the double-side static torque meets the requirement.	DBSD-P	Ⓢ	Ⓢ	Ⓢ
Door Interlock Short Safety Protection	In auto mode, if the door interlock switch is detected shorted, the elevator will stop to protect passengers.	DSSP	Ⓢ	Ⓢ	Ⓢ
Energy Feedback	Power generated during operation is fed into to the electrical network in the building to save energy.	EFDBK	Ⓢ	Ⓢ	Ⓢ
Electrical Circuit Safety Protection	If any electrical safety device functions, the elevator will stop.	ESC	Ⓢ	Ⓢ	Ⓢ
Floor Height Measuring	The data of floor height is measured and recorded automatically.	FMR	Ⓢ	Ⓢ	Ⓢ
Inspection Operation	This Inspection Operation mode is for maintenance staff.	INSP	Ⓢ	Ⓢ	Ⓢ
Over-Current Protection	The elevator stops when over-current is detected in the rectifier or inverter.	OCP	Ⓢ	Ⓢ	Ⓢ
Over-Speed Protection	The elevator stops when the car travels at a speed over the allowed value.	OSP	Ⓢ	Ⓢ	Ⓢ
Over-Temperature Protection	The elevator stops when the motor is detected overheated	OTP	Ⓢ	Ⓢ	Ⓢ
Over-voltage Protection	The elevator stops when over-voltage is detected in the rectifier or inverter.	OVP	Ⓢ	Ⓢ	Ⓢ
Power Failure Protection	The elevator stops in case of faults like open phase, phase loss or under-voltage.	PF	Ⓢ	Ⓢ	Ⓢ
Power-on Relleving	If the car stops in the door zone but not in the leveling zone in case of power failure, it will relevel to the leveling position after the power is recovered.	POR	Ⓢ	Ⓢ	Ⓢ
Reverse Operation Protection	The elevator stops when the elevator is detected running reversely.	RSP	Ⓢ	Ⓢ	Ⓢ
Single-Side Static Torque Detect (Manual)	The elevator enters the Single-Side Static Torque Detect (Manual) mode via manual operation. The elevator releases one brake and keeps other brakes in holding state to check whether the static torque meets the requirements.	SBSD-M	Ⓢ	Ⓢ	Ⓢ
Selector Correction	The selector is corrected during elevator operation.	SC	Ⓢ	Ⓢ	Ⓢ
Safe Parking	When the elevator stops outside the door zone, the controller will perform safety detection. If the starting requirements are met, then the elevator will stop at the nearest floor with doors open.	SFL	Ⓢ	Ⓢ	Ⓢ
Stop Open	The elevators will automatically open its doors after it stops.	SO	Ⓢ	Ⓢ	Ⓢ
Inverter High-Temperature Detection	The elevator stops when over-heat is detected in the inverter.	THMF	Ⓢ	Ⓢ	Ⓢ
Terminal Slowdown	The car is forced to slowdown by the system to realize normal landing, if the speed does not decrease to the limit when the car reaches the terminal.	TSD	Ⓢ	Ⓢ	Ⓢ
Unintended Car Movement Protection	When the landing doors are not locked and the car doors are not closed, this function makes the car come to an emergency stop in the event of unintended car movement from the landing as a result of the failure of any component of the traction machine or drive control system.	UCMP	Ⓢ	Ⓢ	Ⓢ
Under Speed Protection	The elevator stops when the car travels at a speed under the allowed value.	USP	Ⓢ	Ⓢ	Ⓢ

■ Operational and Service Features					
Automatic Bypass	When the car load exceeds 80% of rated load, it ignores other hall calls automatically to avoid useless stop and increases the efficiency of car traveling.	ABP	Ⓢ	Ⓢ	Ⓢ
Attendant Service	The normal operation of an elevator can be handled by an attendant, including controlling the opening and closing of doors, changing the travel direction, and selecting bypass.	AS	Ⓢ	Ⓢ	Ⓢ
Bypass	All hall calls are bypassed when the attendant serves and activates the 'Bypass' button.	BP*2	Ⓢ	Ⓢ	Ⓢ
Car Computer Back Up Operation	When the computer of the main operating panel, car top station or door operator has exceptions, the elevator stops at the nearest floor and cannot start again.	CCBK	Ⓢ	Ⓢ	Ⓢ
Reverse Car Call Canceling	In auto mode, when a car finally responds to the last car call, all registered car calls of the opposite traveling direction will be cancelled simultaneously.	CCC	Ⓢ	Ⓢ	Ⓢ
Car Fan Shut Off-Automatic	The car fan will be automatically shut off to save energy after the car is on standby for some time with no direction.	CFO-A	Ⓢ	Ⓢ	Ⓢ
Car Fan Shut Off-Button	The fan is shut off via the buttons on the operating panel.	CFO-B	Ⓢ	Ⓢ	Ⓢ
Car Light Shut Off-Automatic	The car light will be automatically shut off to save energy after the car is on standby for some timewith no direction.	CLO-A	Ⓢ	Ⓢ	Ⓢ
Car Light Shut Off-Button	The light is shut off via the buttons on the operating panel.	CLO-B	Ⓢ	Ⓢ	Ⓢ

Ⓢ Blue refers to standard features. Ⓢ Pink refers to optional features.

功能名称	功能描述	功能代号	1C-2BC	2C-SM21	2C-4C-ITS-21
■ Operational and Service Features					
Continuity of Service	To ensure normal operation of elevators in a whole group, when one elevator cannot respond to registered hall calls, it will be excluded from hall call service, and service is provided by other elevators.	COS	—	Ⓢ	Ⓢ
Elevator Fault Diagnosis	This function is to diagnose the exceptions and faults that occur during elevator operation.	EFD	Ⓢ	Ⓢ	Ⓢ
Emergency Exit Switch	This switch is used for test the conditions of the emergency exit.	EXIT SW*3	Ⓢ	Ⓢ	Ⓢ
False Car Call Canceling - Automatic	If the number of car calls registered differs from the number of passengers, all calls are cancelled to avoid unnecessary stops.	FCC-A*4	Ⓢ	Ⓢ	Ⓢ
False Car Call Canceling - Car Button Type	If a wrong Car Call is pressed by mistake, this button can be pressed twice to cancel the call.	FCC-P*5	Ⓢ	Ⓢ	Ⓢ
Automatic Hall Call Registration	When one elevator cannot take all passengers, the hall buttons remain registered, and the system will assign another elevator to provide service.	FSAT	Ⓢ	Ⓢ	Ⓢ
Group Control Backup Service	This function is to maintain the service of each elevatorwhen group control does not work due to failure of the group control controller or failure of communication between the group control and each elevator.	GCBK	—	—	Ⓢ
Hall Computer Back Up Operation	When the hall computer has an exception, the elevator stops at the nearest floor and cannot start again.	HCBK	Ⓢ	Ⓢ	Ⓢ
Hall Out-of-service Operation	The elevator starts or stops via the RUN/STOP key switch installed in the specified hall.	HOS	Ⓢ	Ⓢ	Ⓢ
Independent Service	An Independent switch is used to enable the car to respond only to car calls without interrupting service.	IND	Ⓢ	Ⓢ	Ⓢ
No Start Alarm	When hall calls and car calls are registered but the elevator cannot start at the pre-set time, the assigned hall calls are cancelled but car halls remain. The exception light is on.	NST*6	Ⓢ	Ⓢ	Ⓢ
Next Landing	When the elevator arrives at the destination floor, if the car doors cannot be opened completely, the elevator will close the doors and go down to the next floor until the doors are opened completely, and then it returns to normal operation.	NXL	Ⓢ	Ⓢ	Ⓢ
Overload Holding Stop	When the car is overloaded, the elevator keeps doors open and the buzzer in the car sounds.	OLH	Ⓢ	Ⓢ	Ⓢ
Secret Call Service - IC Card Type	The buttons of certain specified floors can only be registered via IC card.	SCS-IC*7	Ⓢ	Ⓢ	Ⓢ

■ Emergency Operation Features					
Car Emergency Lighting	When the normal lighting power source is shut, the car emergency lighting will be provided at once.	ECL	Ⓢ	Ⓢ	Ⓢ
Emergency Landing	This device provides power supply in case of power outage. The car will run to the nearest floor, level and keep doors open, and passengers can leave safely.	ELD*8	Ⓢ	Ⓢ	Ⓢ
Emergency Bell	When this button is pressed in case of emergency, the bell or the intercom device rings.	EMB	Ⓢ	Ⓢ	Ⓢ
Fireman's Emergency Operation	When the FE switch is activated, all hall calls and car calls are cancelled. The elevator returns to the specified floor and open doors, and is available for fireman's service.	FE*9	Ⓢ	Ⓢ	Ⓢ
Fire Emergency Return	If the Fire Emergency Return switch is activated, all hall calls and car calls are cancelled. The elevator immediately returns to the specified floor and stops with doors open.	FER*9	Ⓢ	Ⓢ	Ⓢ
Elevator Monitoring System	This system uses computers to monitor the operation and positions of an elevator, and when necessary gives commands.	SmartEye*10	Ⓢ	Ⓢ	Ⓢ

■ Door Operation Features					
Multi-Beam Protection	A safety device to detect whether there are passengers in the elevator using multiple infrared light beams mounted at the entrance of the elevator. The doors open if there are passengers.	AMS*11	Ⓢ	Ⓢ	Ⓢ
Door Close Limit Switch	When the car doorscannot be fully closed, the doors will reopen reversely.	CLTS	Ⓢ	Ⓢ	Ⓢ
Double Door Operation	When car doors are in open state, if there is no car call and hall call in forward direction and the hall call in the reverse direction of this floor has been registered, the car doors will close and then immediately open again.	DDOP	Ⓢ	Ⓢ	Ⓢ
Extended Door-openButton	When the Door Open button is pressed for three seconds, the doors will remain open longer.	DKO-T	Ⓢ	Ⓢ	Ⓢ
Door Load Detector	When the doors cannot be fully opened or closed due to overload, the doors immediately reverse.	DLD	Ⓢ	Ⓢ	Ⓢ
Not Door Open Feature	If car doors are blocked while opening, the door will be closed at once.	DONG	Ⓢ	Ⓢ	Ⓢ
Automatic Door-openTime Adjustment	The time doors are open will automatically be adjusted depending on whether the stop wascalled from the hall or the car.	DOT	Ⓢ	Ⓢ	Ⓢ
Door-Close Torque Control	When car doors encounter extra resistance while closing, the door system will automatically increase the torque.	DTC	Ⓢ	Ⓢ	Ⓢ
Expediting Door Close	After the car has stopped at a landing and the doors has opened, the car doors will be closed immediately when the Door Close button is pressed.	EDC	Ⓢ	Ⓢ	Ⓢ
Multi-Beam Door Sensor with Safety Edge	It is safety edge with multiple beams to provide double protection using multiple beams and safety edge. During door closing, when a passenger or object is detected, the doors will open again.	MBS*11	Ⓢ	Ⓢ	Ⓢ
Door Nudging Feature-With Buzzer	If the period for keeping the door open exceeds the pre-set time, the elevator will temporarily ignore the non-contact door sensors and give a warning sound to remind the passengers, and try to close the door.	NDG*12	Ⓢ	Ⓢ	Ⓢ
Repeated Door-close	Should an obstacle prevent the doors from closing, the doors will repeatedly open and close untilthe obstacle is cleared from the doorway.	RDC	Ⓢ	Ⓢ	Ⓢ
Reopen with Hall Button	Closing doors can be reopened by pressing the hall button corresponding to the travelingdirection of the car.	ROHB	Ⓢ	Ⓢ	Ⓢ

■ Signal and Display Features					
Voice Announcer-CN	The Voice Announcer will inform passengers of relevant elevator information in Chinese.	AAN-S01*13	Ⓢ	Ⓢ	Ⓢ
Voice Announcer-CN/EN	The Voice Announcer will inform passengers of relevant elevator information in Chinese and English in turn.	AAN-S02*13	Ⓢ	Ⓢ	Ⓢ
Voice Announcer-EN	The Voice Announcer will inform passengers of relevant elevator information in English.	AAN-S03*13	Ⓢ	Ⓢ	Ⓢ

Ⓢ Blue refers to standard features. Ⓢ Pink refers to optional features.

Feature	Description	Code	1C-2BC	2C-SM21	2C-4C-ITS-21
Signal and Display Features					
Car Arrival Chime	Electronic chimes sound to indicate that a car will soon arrive. (The chimes are mounted either on the top and bottom of the car.)	AECC	⊙	⊙	⊙
Signal Interface BA	This device outputs signals of basic operation state of the elevator.	BA*14	⊙	⊙	⊙
Bypass Signal Light	The Hall Position Indicator shows that the elevator is in "Bypass" state.	BPL*15	⊙	⊙	⊙
Direction Arrows in Car	The arrows in the car indicate the travel direction of the elevator.	DAC	Ⓢ	Ⓢ	Ⓢ
Direction Arrows in Hall	The arrows in the hall indicate the travel direction of the elevator.	DAH	Ⓢ	Ⓢ	Ⓢ
Door-Close Button Response Light	The Door-Close button light illuminates at the same time when this button is pressed.	DCR	Ⓢ	Ⓢ	Ⓢ
Door-Open Button Response Light	The Door-Open button light illuminates at the same time when this button is pressed.	DOL	Ⓢ	Ⓢ	Ⓢ
Elevator Counter/Timer	This device records the number of runs and running time of the elevator.	ECT	Ⓢ	Ⓢ	Ⓢ
Fire Emergency Operation - Completed	When the Fireman's Emergency Operation is activated and the elevator runs to specified return floor, the elevator outputs a "Completed" signal.	FE-CP*16	⊙	⊙	⊙
Fire Emergency Return - Completed	At the end of Fire Emergency Return operation, the elevator will output a "Completed" signal.	FER-CP*17	⊙	⊙	⊙
Flashing Hall Button Lantern	When the elevator stops at a landing and starts to open the doors, the Hall Call Button Light of the same direction flashes to remind passengers that the car has arrived; when the doors are closed completely, the Light goes off.	FHBL	Ⓢ	Ⓢ	Ⓢ
Hall Position Indicator	The dot-matrix hall position indicator will display information with low brightness when there is no call, and with normal brightness when the call button of the floor is activated, thus saving energy and extending the service life.	HIES	⊙	⊙	⊙
Interphone	A device allows communication between passengers inside a car, at the top or in the pit and personnel in the machine room or the monitoring room in case of emergency.	ITP*18	Ⓢ	Ⓢ	Ⓢ
ITV Cable (Analog)	The cable used for video camera(analog) installed in the car for the user.	ITV-A*19	⊙	⊙	⊙
ITV Cable (Digital)	The cable used for video camera(digital) installed in the car for user.	ITV-D*19	⊙	⊙	⊙
ITV Cable (SmartEye)	The cable used for video camera of the SmartEye system.	ITV-S*19	⊙	⊙	⊙
Car Overload Indication	When the elevator is overloaded, the overload indication is lit.	OLHL	⊙	⊙	⊙

Group Control Features					
Congested-floor Service	Cars are allocated to congested floors where meeting rooms exist in order to meet increased demands for travel.	CFS	—	—	⊙
Down Peak Service	Cars are allocated to the top floor with higher priority during office leaving time in order to meet increased demands for downward travel.	DPS	—	—	⊙
Lunchtime Service	During lunchtime, calls for a restaurant floor are served with higher priority in order to take passengers into and out from the restaurant.	LTS	—	—	⊙
Main Floor Parking	An available car always parks on the main (lobby) floor.	MFP	⊙	—	—
Overall Spotting	Available cars in the group control always parks on the main floor and middle floors.	OHS	—	Ⓢ	Ⓢ
Prevention of Simultaneous Running	This function prevents increased noise level in the cars when elevators installed in a shared hoistway are running at the same time in fast speed zone.	PRS	—	—	⊙
Peak Traffic Control	To alleviate the temporary heavy traffic, a floor which temporarily has the heaviest traffic (top floor or main floor) is served with higher priority over other floors.	PTC	—	—	⊙
Up Peak Service	Cars are allocated to the main floor with higher priority during office starting time and when demands for upward travel from the main floor are increased.	UPS	—	—	⊙

Ⓢ Blue refers to standard features. ⊙ Pink refers to optional features.

Notes:

- *1. Optional if traveling height is less than 30m (include 30m). Standard if traveling height is more than 30m.
- *2. Standard for AS.
- *3. When hoistway safety doors are available.
- *4. Optional when the number of landings equals or is more than 6 and SCS-IC is not available.
- *5. Optional when SCS-IC is not available.
- *6. Signals of exceptions are output by SmartEye.
- *7. SMEC provides the whole set. If "IC-card" is used, please consult our local agents.
- *8. Optional when distance between adjacent landings does not exceed 12 m.
- *9. It is considered that the elevator be able to run from the top terminal landing to the evacuation floor in 60 seconds. The time is estimated as (Distance from the top terminal floor to FER return floor/Rated speed + 9 seconds). This feature is optional for general elevators. Elevators with this feature do not conform to standards for fire elevators GB/T-26465. Since elevators conforming to GB/T-26465 have special requirements for the environment, buildings, power supply and water resistance. Please consult our sales department to order such elevators.
- *10. Sign SmartEye Contract with SMEC.
- *11. Either AMS or MBS.

- *12. Optional for AMS and standard for MBS.
- *13. Select AAN-S01, AAN-S02 or AAN-S03 at most.
- *14. Signals output by BA include "up", "down", "hall code" and "comprehensive fault". The output signal terminals are in the control panel of the machine room. BA outputs these signals through dry contact or RS485 serial communication.
- *15. Standard for ABP and BP.
- *16. Standard for FE; output by the control panel.
- *17. Standard for FER; output by the control panel
- *18. Wires and cables from the machine room to the monitoring room provided and installed by the owner. For details of interphone specifications, see LEHY-III-PS3.
- *19. Select ITV-A, ITV-D or ITV-S at most. When ITV is available, confirm the responsibility of cabling with the user.
For ITV-A, the owner is responsible for laying the coaxial cables from the monitoring room to the control panel of the machine room, with interfaces in the car and the machine room, for connecting the analog video device in the car.
For ITV-D, the owner is responsible for configuring the Ethernet from the monitoring room to the control panel of the machine room, with interfaces in the car and the machine room, for connecting the digital video device in the car.
For ITV-S, the owner shall complete cabling according to SmartEye.

Safety and Harmony

Technology Changes Our Life Technology Leads the Future
Shanghai Mitsubishi Elevator Is Always With You



SMEC Layout
Scan this QR code to find more

LEGY-III Civil Engineering

Scan the QR code of the mini-program and then select:

- Search elevator
- Search shaft by elevator type
- Machine-room available
- Select "LEHY-III-S" for elevator type



Certified as "energy efficient" by TÜV Rheinland

Shanghai Mitsubishi Elevator Co.,Ltd.

Address: No.811 Jiangchuan Road.Minhang,Shanghai,China

Tel: +86-21-24083030/64303030

Fax: +86-21-24083088

Post: 200245

Overseas Business

Tel: +86-21-24083482

Fax: +86-21-24083488

E-mail: overseasbiz@smec-cn.com



<https://www.smec-cn.com/em>



Specifications subject to change without notice

Printed in Aug.2024 (EN-B)